

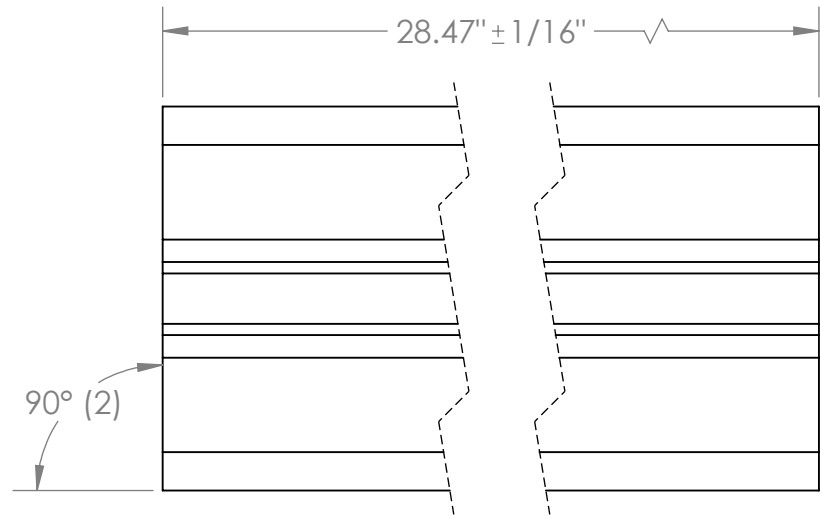

REVISION HISTORY			
REV.	DESCRIPTION	DATE	DRAWN BY
1	ORIGINAL PRINT	12/10/2025	E. SCIME

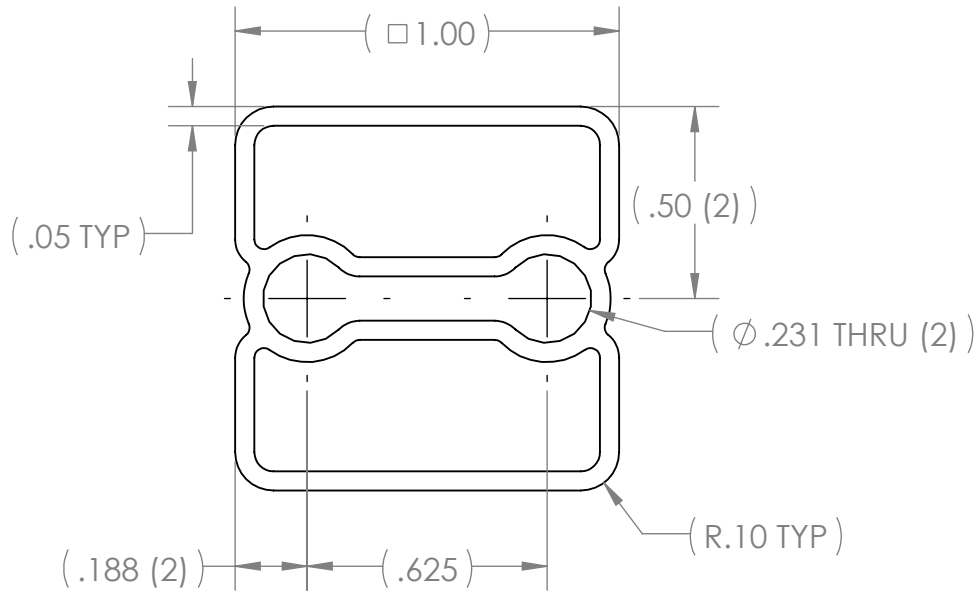

\*\*\* SEE CAD FOR ADDITIONAL TOOLPATH INFO\*\*\*

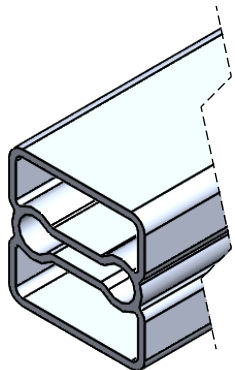

UNLESS OTHERWISE SPECIFIED:		COMMENTS:			
<b>DIMENSIONS ARE IN INCHES</b>		DUAL DIMENSIONS ARE IN MILLIMETERS.			
TOLERANCES:		BREAK ALL SHARP EDGES.		TITLE:	
FRACTIONAL	±1/16			28.47IN PEANUT	
ANGULAR: MACH	±1°				
ANGULAR: BEND	±5°				
ONE PLACE DECIMAL	±0.1				
TWO PLACE DECIMAL	±0.01				
THREE PLACE DECIMAL	±0.005				
FOUR PLACE DECIMAL	±0.0005				
MATERIAL ex-3090		CHECKED	NAME	DATE	SIZE
6063-T6 AL		ENG APPR.	PY	12/10/25	DWG. NO.
FINISH DEBURRED		MFG APPR.			am-3090-2847
DO NOT SCALE DRAWING		Q.A.			1
				SCALE: 2:1	SHEET 1 OF 1